

DGS-1026MP

26-PORT UNMANAGED POE SWITCH



Table of Contents

About This Guide	1
Terms/Usage.....	1
Copyright and Trademarks	1
Product Introduction	2
Package Contents.....	2
Product Overview.....	2
Front Panel	2
Rear Panel.....	2
Indicator LEDs.....	3
Hardware Installation	4
Installation Precautions.....	4
Grounding the Switch.....	4
Attaching the Rubber Feet	4
Mounting the Switch in a Rack.....	5
Powering on the Switch.....	6
Connect to an End Node	6
Connect to a Hub or Switch.....	7
Connect to a Network Backbone or Server	7
Understanding the Switch's Features	8
Power Over Ethernet (PoE)	8
Hardware Specifications	9
Key Components / Performance	9
Ports	9
Port Standards.....	9
Physical & Environment	9
Emission (EMI) Certifications	9
Safety Certifications.....	9
Features	9
General Features.....	9
PoE Features.....	9
Appendix B - Regulatory Statements	10

About This Guide

This guide provides instructions to install the D-Link DGS-1026MP 26-Port Unmanaged PoE Switch.

Terms/Usage

In this guide, the term “Switch” (first letter capitalized) refers to the DGS-1026MP, and “switch” (first letter lower case) refers to other Ethernet switches. Some technologies refer to the terms “switch”, “bridge” and “switching hubs” interchangeably, and all are commonly accepted for Ethernet switches.



A **NOTE** indicates important information to use the device properly.



A **CAUTION** indicates potential property damage or personal injury.

Copyright and Trademarks

Information in this document is subjected to change without notice.

© 2021 D-Link Corporation. All rights reserved.

Reproduction in any manner whatsoever without the written permission of D-Link Corporation is strictly forbidden.

Trademarks used in this text: D-Link and the D-LINK logo are trademarks of D-Link Corporation.

Other trademarks and trade names may be used in this document to refer to either the entities claiming the marks and names or their products. D-Link Corporation disclaims any proprietary interest in trademarks and trade names other than its own.

Product Introduction

The DGS-1026MP is an unmanaged switch with 24 10/100/1000 Mbps ports and 2 Gigabit combo uplink ports. The first 24 10/100/1000 Mbps ports of the DGS-1026MP support IEEE 802.3af/at Power over Ethernet (PoE) and are capable of supplying up to 30 watts of power per port. The DGS-1026MP is easy to install and requires no configuration. With these features combined, the DGS-1026MP provides an ideal solution for Small and Medium Business (SMB) users who have limited budgets but require PoE capability in a switch.

Package Contents

Open the shipping carton and carefully unpack the contents. Please consult the packing list to make sure all items are present and undamaged.

- One D-Link DGS-1026MP 26-Port Unmanaged PoE Switch
- One power cord
- One power cord retainer
- One rack-mount kit and rubber feet
- One Quick Start Guide

If any item is found missing or damaged, please contact your local retailer for replacement.

Product Overview

Front Panel

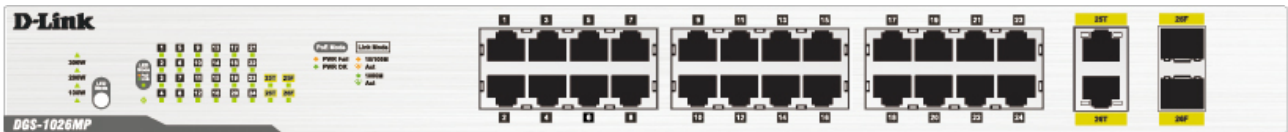

Figure – DGS-1026MP Front Panel

Item	Description
LED MODE	Press to change the port LEDs to display the PoE status or the link status. The color of the LED Mode light will indicate which LED status display is currently active. Green LEDs means the Switch is currently showing the Link/Act/Speed status of the ports, while amber LEDs display the PoE status of the ports. Please refer to the table in the section Indicator LEDs for more detailed information on the LED Mode function.
Ports 1 to 24	These are 10/100/1000 Mbps PoE-capable ports used for connecting Ethernet devices and PoE-powered devices.
Ports 25 to 26	These are 1000 Mbps/SFP combo ports. When using one interface of these combo ports, the other interface in the pair will become unavailable. For example, using the SFP interface on port 25 will render the RJ45 interface on port 25 unavailable.

Table 1 – Front panel connector description

Rear Panel



Figure 1 – DGS-1026MP Rear Panel

Item	Description
Kensington Security Lock	The DGS-1026MP adds additional value by providing users with a simple, reliable, built-in security solution to prevent theft in the form of a Kensington Security Slot on the rear panel of the Switch.
SWITCH GND	This is used to connect the switch to ground.
Power Cord Retainer Slot	This is used for securing the power cord retainer to the switch.
AC Power Connector	The AC power cord (included in the package) can be plugged into this receptacle to supply the switch with 100-240 VAC power at 50-60 Hz.

Table 2 – Rear panel connector description

Indicator LEDs

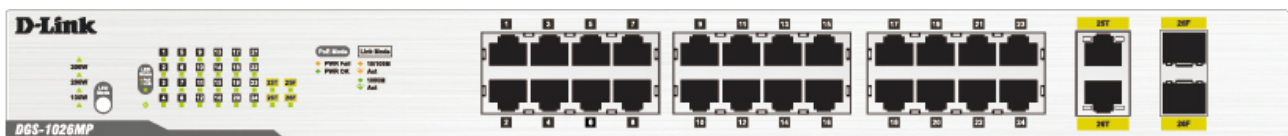

Figure 3 – DGS-1026MP Front panel LEDs

LED	Status	Description
PoE Power Budget	Solid red	(LED above “ 300W ”) The total PoE power consumption is between 301 and 370 W
	Solid amber	(LED below “ 300W ”) The total PoE power consumption is between 201 and 300 W.
	Solid green	(LED below “ 200W ”) The total PoE power consumption is between 101 and 200 W.
	Solid green	(LED below “ 100W ”) The total PoE power consumption is between 1 and 100 W.
	Off	There are no PoE-powered devices connected to the switch.
LED Mode	Solid amber	The port LEDs are currently displaying the PoE status. Please refer to PoE Mode in this table for more information.
	Solid green	The port LEDs are currently displaying the port link status. Please refer to Link Mode in this table for more information.
Power	Solid green	The device is powered on.
PoE Mode (Ports 1 to 24)	Solid amber	The power supply on the corresponding port has failed.
	Solid green	The corresponding port is supplying power correctly.
Link Mode (port1~24)	Solid green	There is an active link on the corresponding port at 1000 Mbps.
	Blinking green	Reception or transmission at 1000Mbps
	Solid amber	There is an active link on the corresponding port at 10/100 Mbps.
	Blinking amber	There is traffic on the corresponding port at 10/100 Mbps.
Link Mode (port25~26)	Solid green	There is an active link on the corresponding port at 1000 Mbps.
	Blinking green	Reception or transmission at 1000Mbps

Table 3 – Front panel LED description

Hardware Installation

This chapter provides more detailed instructions for grounding and installing the DGS-1026MP.

Installation Precautions

For safe installation and operation of the Switch, it is recommended to:

- Visually inspect the DC power jack and make sure that it is fully secured to the power adapter.
- Make sure that there is at least 10 cm of space on each side of the Switch to allow for proper heat dissipation and adequate ventilation around the Switch.
- Install the Switch in a site free from strong electromagnetic sources, vibration, dust, and direct sunlight.
- Install the Switch in a cool and dry place. Refer to the technical specifications section of this manual for the acceptable operating temperature and humidity ranges.
- Not place heavy objects on the Switch.

Grounding the Switch

This section describes how to connect the Switch to ground. It is necessary to complete this procedure before powering on the Switch.

Required Tools and Equipment

- One ground screw (this Switch is shipped with this screw already in place on the rear panel of the device).
- Ground cable (not included in the accessory kit): The grounding cable should conform to local and national installation requirements. Commercially available 18 AWG wire is recommended. The length of the cable depends on the proximity of the Switch to proper grounding facilities.
- A screwdriver (not included in the accessory kit).

The following steps explain the procedure for connecting the Switch to a protective ground:

1. Verify that the Switch is powered off.
2. Remove the grounding screw marked **SWITCH GND** from the back of the device and place the #8 terminal lug ring of the grounding cable on top of the ground screw opening, as seen in the figure below.
3. Insert the grounding screw back into the ground screw opening.
4. Using a screwdriver, tighten the ground screw to secure the ground cable to the Switch.
5. Attach the terminal lug ring at the other end of the grounding cable to an appropriate grounding source.
6. Verify that the connection from the ground connector on the Switch to the ground source is secure.



Figure 4 – Attaching a grounding cable

Attaching the Rubber Feet

The DGS-1026MP comes with a strip of four adhesive rubber pads that can be placed on the bottom of the device to prevent the Switch from damaging the surface it is placed on. This allows the Switch to be placed

virtually anywhere. To attach the rubber pads, simply remove them from the adhesive strip and stick one pad on each corner on the bottom panel of the Switch.

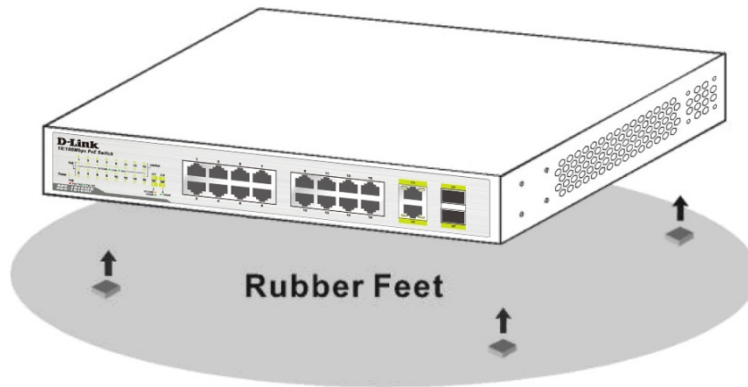

Figure 5 - Attaching the rubber feet

Mounting the Switch in a Rack

The DGS-1026MP can be easily mounted in a rack using the two provided mounting brackets. Make sure that the front panel is exposed in order to view the LEDs. Please refer to the following illustrations:

1. Attach and fasten the rack mounting brackets to each side of the Switch using the included screws.

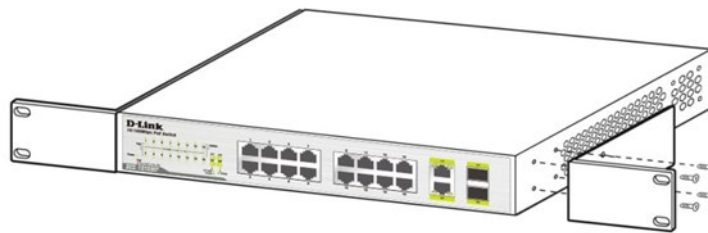

Figure 6 - Attaching the rack brackets

2. Firmly secure the brackets with the Switch to the rack. Please follow the usual safety precautions for rack-mountable products.

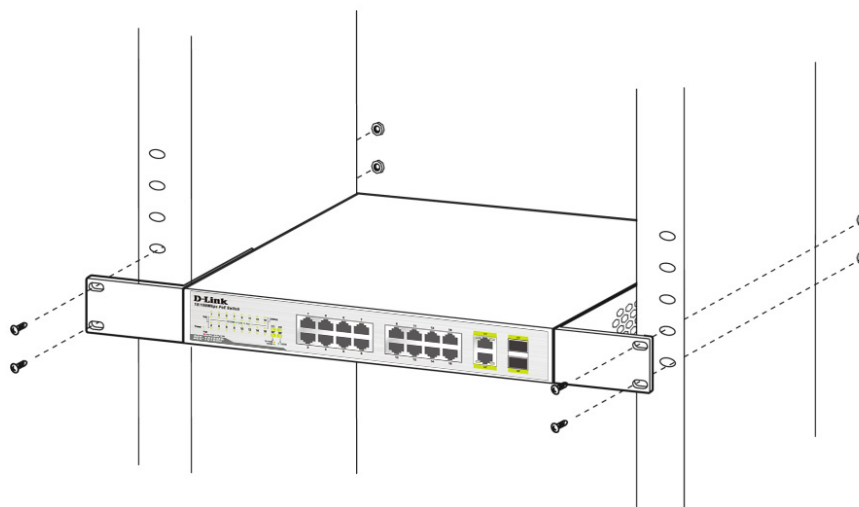

Figure 7 - Securing the Switch to a rack

Powering on the Switch

To power on the Switch, connect the provided power cable to the power socket on the back of the Switch, and connect the adapter side of the cord to a suitable power source.

After the Switch has been powered on, the LED indicators will blink briefly while the system initializes.

As a precaution, in the event of a power failure it is recommended to unplug the Switch. When power has been restored, plug the Switch back in.

Connect to an End Node

Use a standard Ethernet cable to connect the Switch to PCs with a 10/100/1000 Mbps RJ45 interface, or connect and power remote IEEE 802.3af/at-compliant PoE devices, such as IP cameras or IP phones. The Switch ports will automatically adjust to the hardware characteristics (MDI/MDIX, speed, duplex mode) of the connected device.

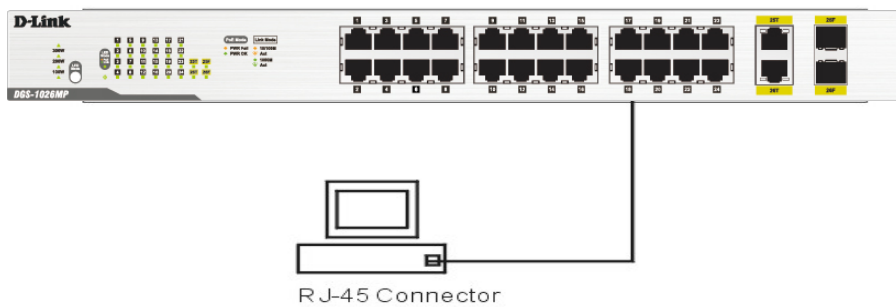

Figure 8 – Connecting the Switch to a node

Connect to a Hub or Switch

Use a straight or crossover cable to connect the Switch to another switch or hub.

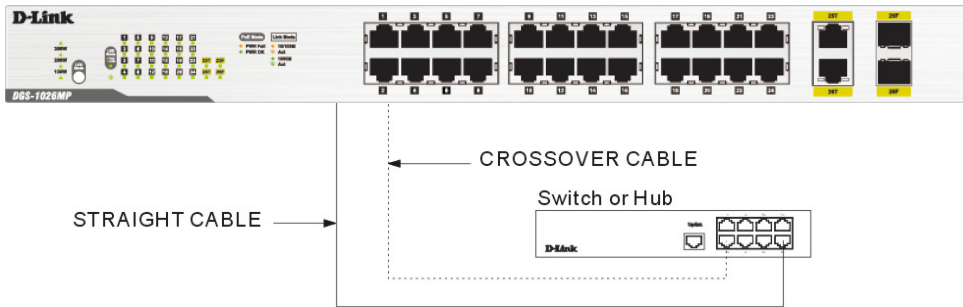

Figure 9 – Connecting the Switch to another switch or hub

Connect to a Network Backbone or Server

Use any port on the device to connect the Switch to a network backbone or network server. When linking to a 1000BASE-T device, the port operates in full-duplex mode.

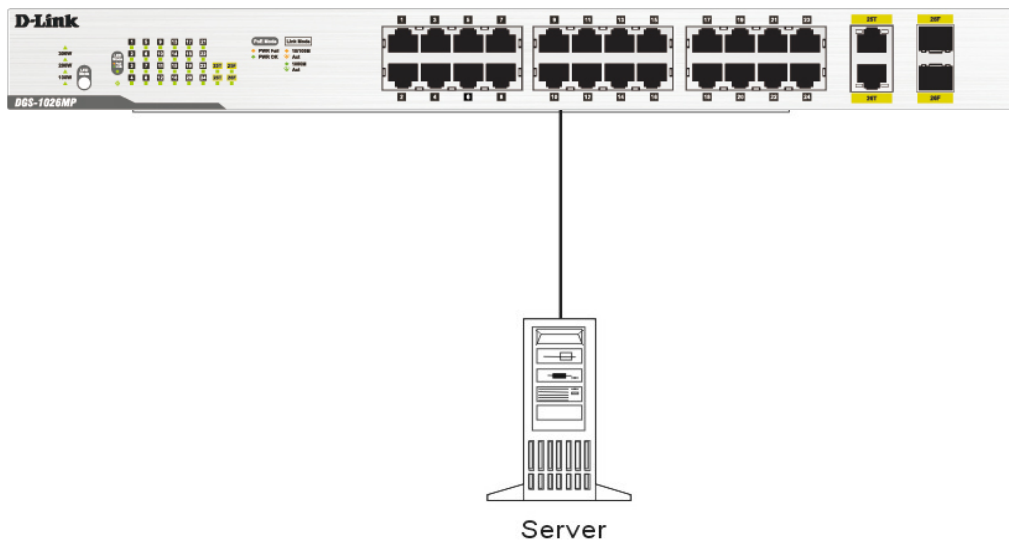

Figure 10 – Connecting the Switch to another switch or hub

Understanding the Switch's Features

Power Over Ethernet (PoE)

The DGS-1026MP supports many PoE features to guarantee the safety and stability of the Switch and the connected powered devices.

PoE Power Budget: The total PoE budget of the DGS-1026MP is limited to a maximum of 370 watts to both protect the Switch and to stabilize the power being transmitted to the PoE-powered devices.

Guard Band: The DGS-1026MP reserves a 7 watts Guard Band to prevent the PoE power supply from exceeding the maximum PoE power budget of 370 watts. When the Switch detects the current PoE output has reached the maximum of 370 watts, and another device is connected to the Switch, the Switch will check which type of device is being connected. If the device is another PoE-powered device, the Switch will disconnect the power on the port with the higher port number in order to power the new device.

PWM Fan Speed Control

The DGS-1026MP supports PWM fan speed control. The fan speeds range from 20% to 100%, with a maximum speed of 9000rpm and a minimum speed of 2000rpm. The speed regulation of the fan is related to the PD load power and is set to 5 speeds. Through the coordination of PD load power and fan speed, the balance between noise and thermal is achieved.

PD Load	Fan Speed
0-60W	2000rpm
90W	3000rpm
120-180W	6750rpm
210-270W	8250rpm
300-370W	9000rpm

Hardware Specifications

Key Components / Performance

- › Switching Capacity: 52 Gbps
- › Max. Forwarding Rate: 38.69 Mpps
- › Forwarding Mode: Store-and-forward
- › Packet Buffer memory: 512 Kbytes

Ports

- › 24 x 10/100/1000BASE-T PoE ports
- › 2 x 1000BASE-T/SFP combo ports

Port Standards

- › IEEE 802.3
- › IEEE 802.3u
- › IEEE 802.3x (Full-duplex Flow Control)
- › IEEE 802.3z
- › IEEE 802.3af/at (ports 1 to 24)

Physical & Environment

- › Dimensions: 440 x 267 x 44 mm
- › Weight: 3.95 kg
- › Internal Power Supply AC input: 100~240 VAC, 50/60Hz
- › Acoustic: 46.89 dB(A) at low speed, 51.9 dB(A) at high speed
- › Operation Temperature: 0 to 50 °C

- › Storage Temperature: -40 to 70 °C
- › Operation Humidity: 0% to 95% RH
- › Storage Humidity: 0% to 95% RH

Emission (EMI) Certifications

- › CE
- › FCC
- › VCCI
- › BSMI

Safety Certifications

- › UL
- › CB
- › LVD
- › BSMI

Features

General Features

- › Surge protection
- › Supports up to 8K MAC addresses

PoE Features

- › IEEE 802.3af/at compliant
- › Supplies up to 30 watts power per port.
- › Total PoE budget: 370 watts.

Appendix B - Regulatory Statements

FCC Warning

This equipment has been tested and found to comply with the regulations for a Class A digital device, pursuant to Part 15 of the FCC Rules. These limits are designed to provide reasonable protection against harmful interference when the equipment is operated in a commercial environment. This equipment generates, uses, and can radiate radio frequency energy and, if not installed and used in accordance with this user's guide, may cause harmful interference to radio communications. Operation of this equipment in a residential area is likely to cause harmful interference, in which case the user will be required to correct the interference at his/her own expense.

Innovation, Science and Economic Development Canada (ISED) Statement

This Class A digital apparatus complies with Canadian ICES-003. Cet appareil numérique de la classe A est conforme à la norme NMB-003 du Canada.

VCCI Warning

この装置は、クラスA情報技術装置です。この装置を家庭環境で使用すると電波妨害を引き起こすことがあります。この場合には使用者が適切な対策を講ずるよう要求されることがあります。

UL Warning

- a) Elevated Operating Ambient Temperature- If installed in a closed or multi-unit rack assembly, the operating ambient temperature of the rack environment may be greater than room ambient. Therefore, consideration should be given to installing the equipment in an environment compatible with the manufacturer's maximum rated ambient temperature (Tmra).
- b) Reduced Air Flow- Installation of the equipment in a rack should be such that the amount of air flow required for safe operation of the equipment is not compromised.
- c) Mechanical Loading- capitalize of the equipment in the rack should be such that a hazardous condition is not achieved due to uneven mechanical loading.
- d) Circuit Overloading- Consideration should be given to the connection of the equipment to the supply circuit and the effect that overloading of circuits might have on over current protection and supply wiring. Appropriate consideration of equipment nameplate ratings should be used when addressing this concern.
- e) Reliable Earthing- Reliable earthing of rack-mounted equipment should be maintained. Particular attention should be given to supply connections other than direct connections to the branch circuit (e.g., use of power strips).
- f) The Installation instructions clearly state that the ITE is to be connected only to POE networks without routing to the outside plant.

BSMI statement

警告使用者: 此為甲類的資訊技術設備，在居住環境中使用時，可能會造成射頻擾動，在這種情況下，使用者會被要求採取某些適當的對策。

Warning:

This is a class A product. In a domestic environment this product may cause radio interference in which case the user may be required to take adequate measures.

Fuse is in the neutral, and that the mains shall be disconnected to de-energize the phase conductors.

This is for power supply: POE-U400D54+12D

CAUTION

DOUBLE POLE/NEUTRAL FUSING

Attention

Fusion bipolaire / neuter

CE Mark Warning

This equipment is compliant with Class A of CISPR 32. In a residential environment, this equipment may cause radio interference.

Avertissement Concernant la Marque CE

Cet équipement est conforme à la classe A de la norme CISPR 32. Dans un environnement résidentiel, cet équipement peut provoquer des interférences radio

